

INSTALLATION

BUILT-IN CONSTRUCTION DETAILS

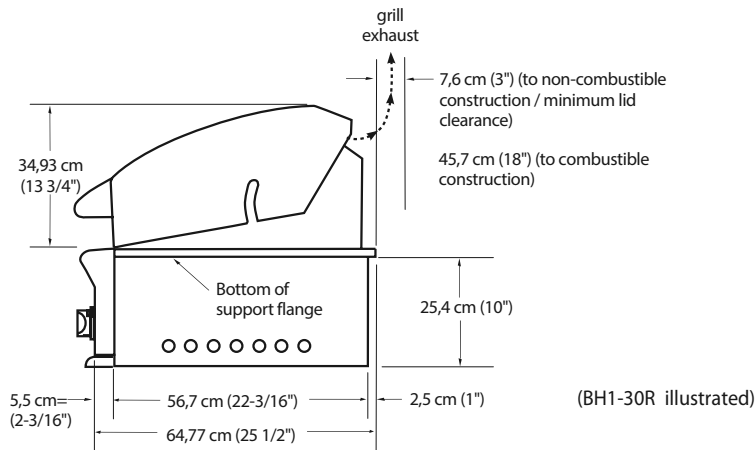

Standard layout for non-combustible enclosure:

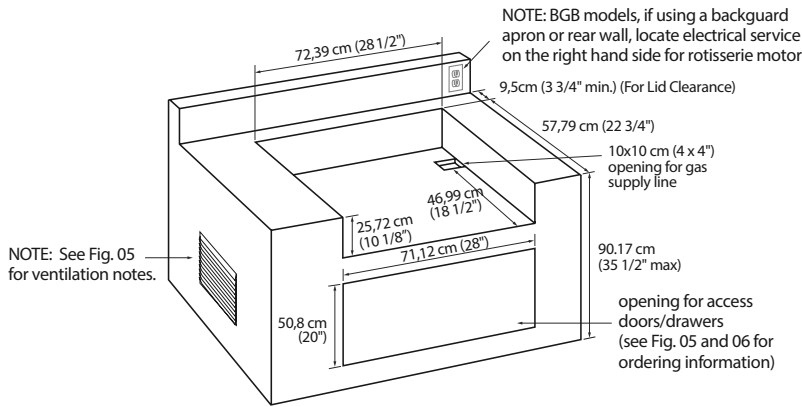

WARNING!
If installing the grill into a non-combustible enclosure, all combustible construction must still be outside the 18 inch / 45,7cm clearance zone. If your island is made of stucco over the top of wooden studs, the wood can not be inside the 18 inch clearance zone to combustible, even though the stucco is what is touching the grill area.

Layout for insulated jacket only - combustible enclosure:

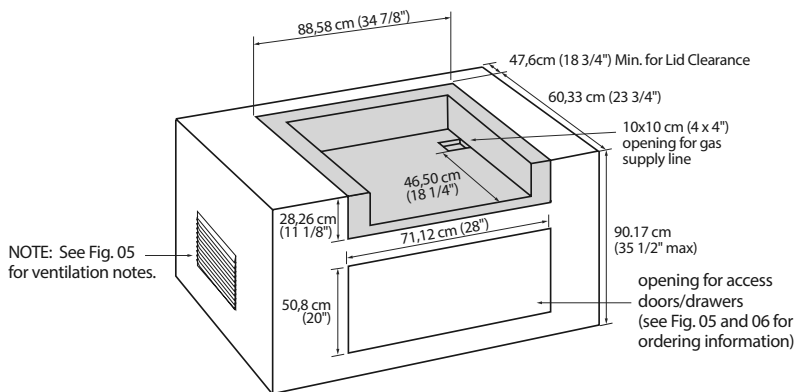

INSULATED JACKET	
Size	Part No.
30	70859

FIG.04

Note:
The gas connection must be visible to the user (through a door opening or similar).
Gas piping and connectors must be clamped within the the enclosure to avoid contact with moving parts and hot surfaces.
Where the gas piping passes through an opening in the enclosure, the piping must be protected for a distance of at least 2" (50mm) either side of the opening.
The gas connector must comply with the Standard for Connectors for Outdoor Gas Appliances & Manufactures Homes, ANSI Z21.75/ CSA 6.27.
The connection must be no longer than 6' (1820mm) in length and be suitable for outdoor installation.

INSTALLATION

BUILT-IN CONSTRUCTION DETAILS

Access Drawers Cutout dimensions

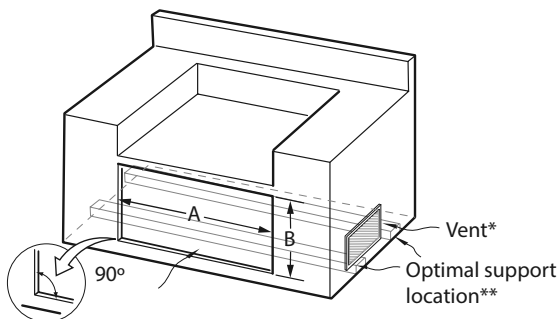

FIG. 05

NOTE: The cutout of each corner should be 90° angle in order for the access drawers to fit properly.

* The enclosure should have ventilation holes to prevent gas build-up in the event of a leak. Refer to ANSI Z21.58 Standard for Outdoor Cooking Gas Appliances, Section 1.7 Enclosures For Self Contained LP-Gas Supply Systems.

** For proper support and drawer operation, insure that support boards are installed per Installation Guide instructions

MODEL NUMBER	A (+0,-1/8)	B (+1/8,-0)	C
ADR2-48	46"	20"	24-1/2" (Min, All Models)
ADR2-36	34"	20"	
ADR2-30	28"	20"	
ADR2-24	22"	20"	

Access Doors Cutout dimensions

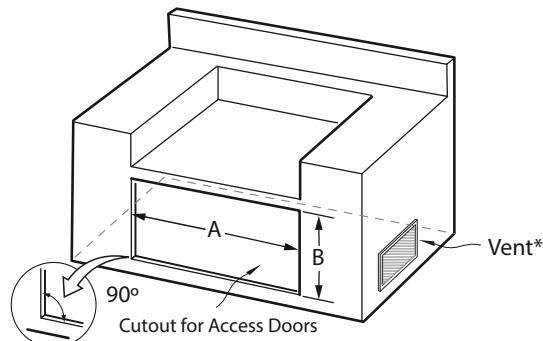

FIG. 06

NOTE: The cutout of each corner should be 90° angle in order for the access drawers to fit properly.

* The enclosure should have ventilation holes to prevent gas build-up in the event of a leak. Refer to ANSI Z21.58 Standard for Outdoor Cooking Gas Appliances, Section 1.7 Enclosures For Self Contained LP-Gas Supply Systems.

MODEL NUMBER	A (+0,-1/8)	B (+1/8,-0)
ADN1-20x48	46"	20"
ADN1-20x36	34"	20"
ADN1-20x30	28"	20"
ADN1-20x24	22"	20"

To order access drawers or doors, please call DCS Customer Care at 1.888.936.7872 for DCS Dealer in your area.