

Built-in Construction Details

Standard layout for non-combustible cavity

IMPORTANT!

If installing the grill into a non-combustible enclosure, all combustible construction must still be outside the 18" (457mm) clearance zone. If your island is made of stucco over the top of wooden studs, the wood can not be inside the 18 inch clearance zone to combustible, even though the stucco is what is touching the grill area.

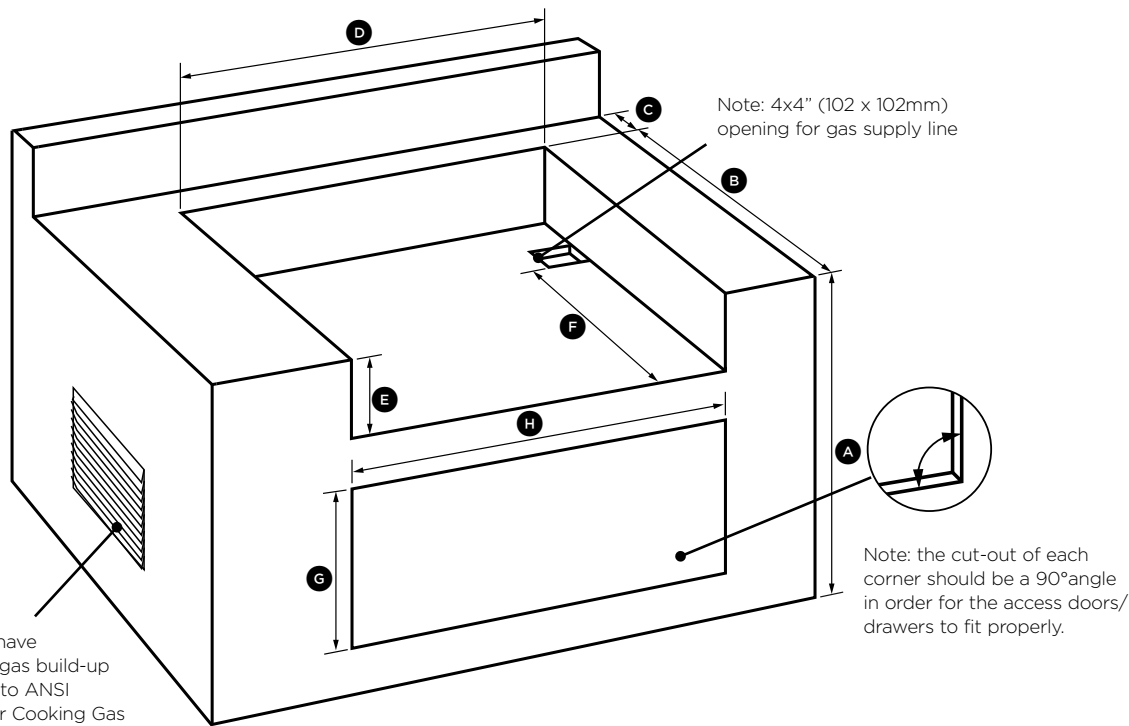

Note: the enclosure should have ventilation holes to prevent gas build-up in the event of a leak. Refer to ANSI Z21.58 Standard for Outdoor Cooking Gas Appliances, Section 1.7 Enclosures For Self Contained LP-Gas Supply Systems.

FIG. 05

CAVITY DIMENSIONS	BE1-48R Inches (mm)	BE1-36R Inches (mm)
Ⓐ Maximum height of enclosure shell	35 1/2" (902)	35 1/2" (902)
Ⓑ Depth of enclosure shell	22 3/4" (578)	22 3/4" (578)
Ⓒ Minimum depth for hood swing	3 3/4" (95)	3 3/4" (95)
Ⓓ Width of enclosure cavity	45 3/4" (1162)	34 1/2" (876)
Ⓔ Height of enclosure cavity	10 1/8" (257)	10 1/8" (257)
Ⓕ Depth to gas supply opening	18 1/2" (470)	18 1/2" (470)
Ⓖ Height of opening for access doors/drawers	20" (508)	20" (508)
Ⓗ Width of opening for access doors/drawers	46" (1168)	34" (864)

INSTALLATION

Built-in Construction Details

Standard layout for cavity including insulated jacket

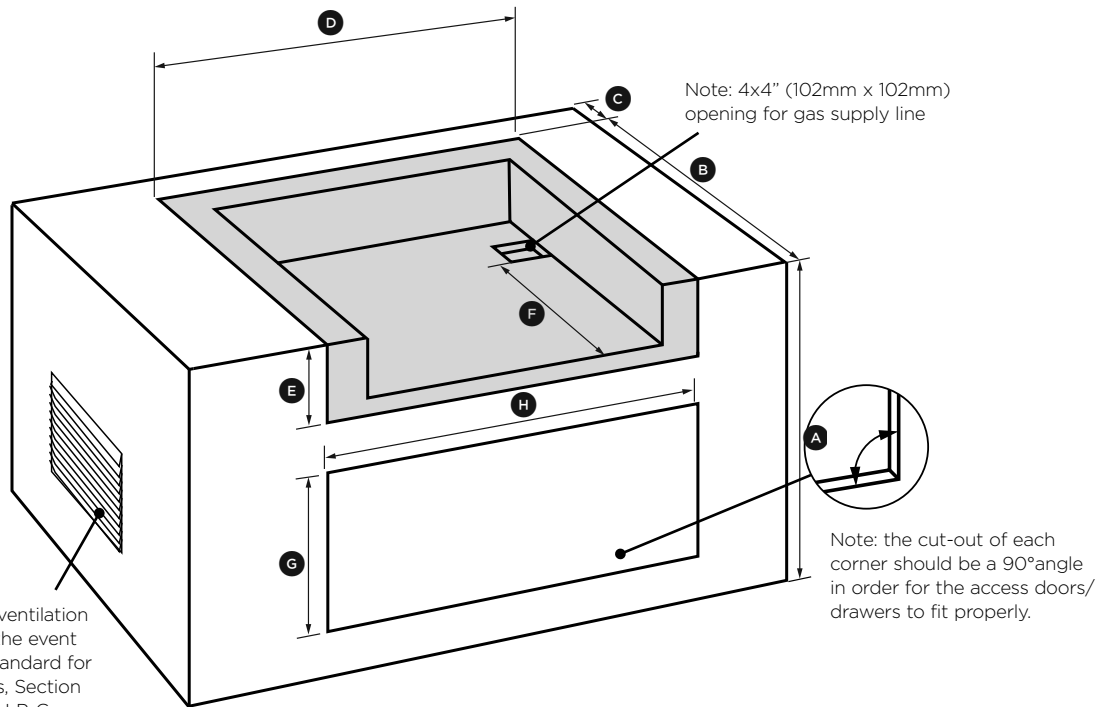

Note: the enclosure should have ventilation holes to prevent gas build-up in the event of a leak. Refer to ANSI Z21.58 Standard for Outdoor Cooking Gas Appliances, Section 1.7 Enclosures For Self Contained LP-Gas Supply Systems.

FIG. 06

CAVITY DIMENSIONS	BE1-48R	BE1-36R
	Inches (mm)	Inches (mm)
Ⓐ Maximum height of enclosure shell	35 1/2" (902)	35 1/2" (902)
Ⓑ Depth of enclosure shell	22 3/4" (578)	22 3/4" (578)
Ⓒ Minimum depth for hood swing	3 3/4" (95)	3 3/4" (95)
Ⓓ Width of enclosure cavity	51 5/8" (1318)	40 1/2" (1029)
Ⓔ Height of enclosure cavity	11 1/8" (283)	11 1/8" (283)
Ⓕ Depth to gas supply opening	18 1/2" (470)	18 1/2" (470)
Ⓖ Height of opening for access doors/drawers	20" (508)	20" (508)
Ⓗ Width of opening for access doors/drawers	46" (1168)	34" (864)

ACCESS DOORS MODEL NUMBER	ACCESS DRAWERS MODEL NUMBER	CAVITY WIDTH	CAVITY HEIGHT
		Inches (mm)	Inches (mm)
ADN1-20x48	ADR2-48	46" (1168)	20" (508)
ADN1-20x36	ADR2-36	34" (864)	20" (508)
ADN1-20x30	ADR2-30	28" (711)	20" (508)
ADN1-20x24	ADR2-24	22" (559)	20" (508)

To order access drawers or doors, please visit www.dcsappliances.com for further details.